

S180D

HEAT RECOVERY VENTILATOR



part #673150



AÉROMATIC S180D

The AÉROMATIC S180D is a heat recovery ventilator of 180 CFM. It is conceived for apartments and condominiums. Its compact conception and its ducts on the top endow it with a big flexibility to install.

The AÉROMATIC S180D offers impressive heat recovery efficiency for such a small case. The electronic Control card offers an electronic calibration of the appliance as well as infinite speeds of operations. This unit the Energy Star requirement.

- Compact
- Flexibility of installation
- Simplified speed adjustment and balancing
- High recovery efficiency
- Integrated Thermal Sensor
- Circulation defrost, to prevent depressurisation
- Inside Lining is aluminum to facilitate cleaning
- Silent
- Very economical
- ENERGY STAR® qualified

Casing

Material : Pre-painted steel 24GA
 Isolation : Fiberglass with FSK
 Drain connection : Ø3/8"
 Duct diameter: Ø6 in
 Height : 24 in
 Width : 27 5/8 in
 Depth : 15 3/4 in
 Weight : 58 lbs

Mount

Suspended by chains with anti-vibration springs or a shelf

Ventilators

Number : 2
 Type : Motorized impeller (backward inclined centrifugal fan)
 Dimensions : Ø190mm X 68.5mm

Electrical Specifications

Tension : 120 VAC
 Frequency : 60 Hz
 Amperage : 1.8 A
 Power : 216 Watt
 Extension Cord: 3 feet with a 3 prongs plug

Control

Low voltage dry contact (24 VAC) for :

- Fan interlock (NO and NC)
- Liquid crystal display electronic humidistat #611227
- Mode Control (exchange or recirculation) #611230
- Humidity Control #611224
- Speed Control (intermittent, high or low speed) #611229
- Timer #611228

Defrost

DEFROST CYCLE TEMPERATURE

Outside temperature		Standard	Extended
Celsius	Fahrenheit	min def/vent	min def/vent
t > -5	t > 23	n.a.	n.a.
-5 > t > -25	23 > t > -13	7/25	10/20
-25 > t	-13 > t	10/22	10/15

- Cycles Controlled by a temperature sensor
- By recirculation

Filters

Number : 2
 Type : Aluminium #612261
 Type options ; Coal #612262 or high efficiency #612263
 Dimensions : 11 3/8 in X 13 5/8 in X 3/8 in

Recovery Core

Material : Polypropylene
 Dimensions : 11 15/16in X 11 15/16in X 13 5/8 in
 Step : 3.0mm and 2.5mm

Warranty

Appliance : limited 5 years
 Core Assembly : limited life time

Norms and certifications

- Conformity to Norms :
 - C22.2 no113
 - UL 507



846, de la Station, bureau 101 - Saint-Léonard d'Aston (Québec) - Canada J0C 1M0
 T 819.399.3400 1.800.262.0916 - F 819.399.4001 - info@air2000.ca - www.air2000.ca

S180D

HEAT RECOVERY VENTILATOR



Ventilator performance

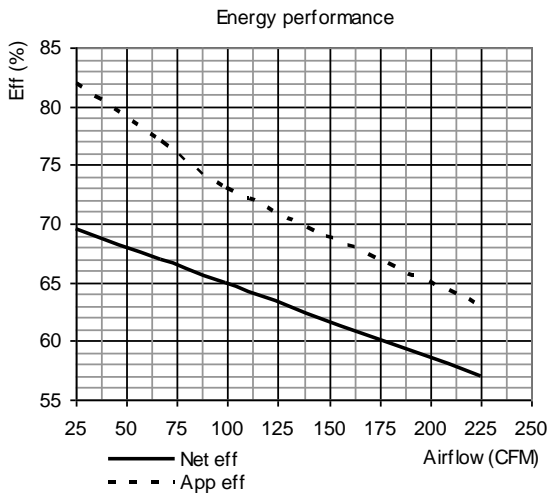
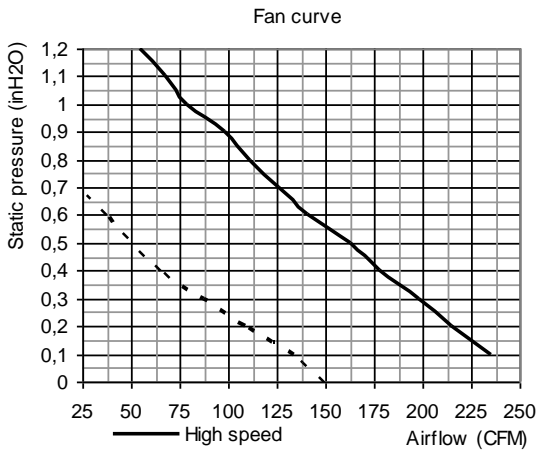

Dimensions

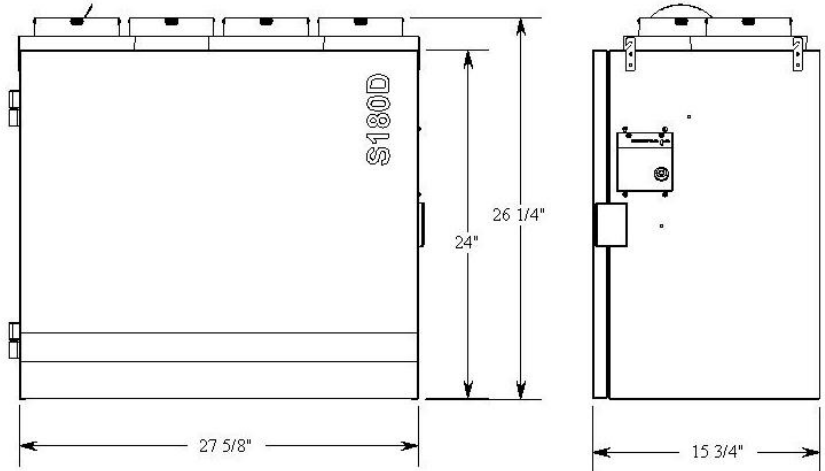
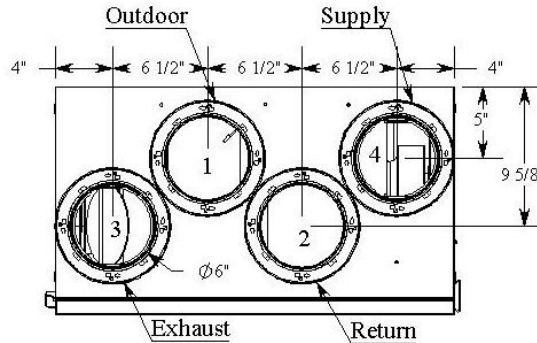

ENERGY PERFORMANCE

	SUPPLY TEMPERATURE		NET AIR FLOW		POWER CONSUMED WATTS	SENSIBLE RECOVERY EFFICIENCY	APPARENT SENSIBLE EFFECTIVENESS	LATENT RECOVERY/MOISTURE TRANSFER
	°C	°F	L/S	CFM				
HEATING	0	32	32	67	70	67	77	0.02
	0	32	47	99	82	65	73	0.01
	-25	-13	33	70	95	82	60	0.01



Submitted by :		Date :	Project :
Qty :	Model # :	Comments :	Location :
			Architect :
			Engineer :
			Contractor :

846, de la Station, bureau 101 - Saint-Léonard d'Aston (Québec) - Canada J0C 1M0
 T 819.399.3400 1.800.262.0916 - F 819.399.4001 - info@air2000.ca - www.air2000.ca