

846, de la Station - St-Leonard d'Aston (Québec) - Canada J0C 1M0
Phone. (819) 399-3400 - fax (819) 399-4001 - info@air2000.ca

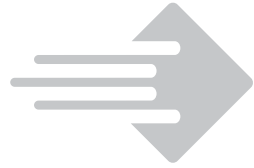

air 2000

Because **air** is **vital**

INSTALLATION INSTRUCTION & OWNER'S GUIDE

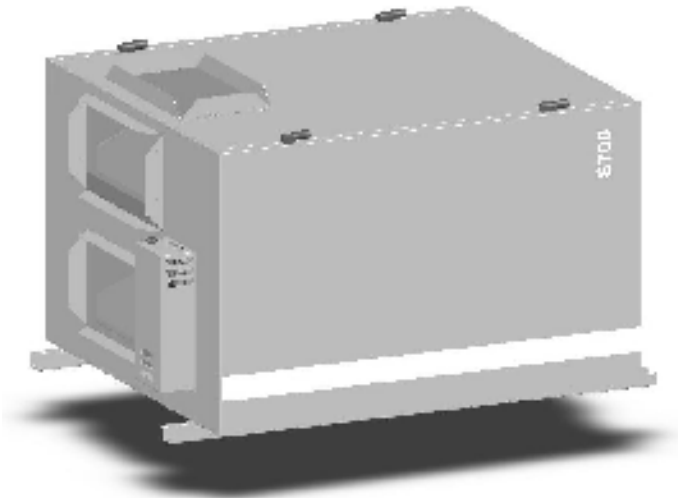

Air exchanger with heat recovery Light industrial

Série S700 - S1100

E700 - E1100

Read carefully and save these instructions.

a Table of contents

1 Welcome

a	Table of contents	2
b	Introduction	3
c	Air exchanger with heat recovery	3

2 Installation preliminaries

a	Box contents	4
b	Installation kit contents	4

3 Location

a	Of the unit	5
b	Of inlet grilles	5
c	Of diffusers	5
d	Of the humidity control	5

4 Installation

a	Of the unit	6
b	Of the exhaust louver	6
c	Of the inlet louver	6
d	Of the humidity control	6
e	Of the ductwork	7
f	Air balancing	7
g	Unit connection	8-9
h	Unit configuration	10

5 Operation

a	Unit	11
b	Hygrostat	12-16
c	Timer	17
d	Maintenance	17

6 General information

a	Technical sheet for SERIES S700	18-19
b	Technical sheet for SERIES E700	20-21
c	Technical sheet for SERIES S1100	22-23
d	Technical sheet for SERIES E1100	24-25
e	Warranty	26
f	Additional information	27
g	Product information	27

b Introduction

You are now the proud owner of an air exchanger. AIR2000 would like to thank you for purchasing this unit which, if you carefully follow the instructions in this guide, will provide you with years of comfort.

First fill the product information section at the end of this guide. Those data are necessary for any claim regarding the warranty.

c Air exchanger with heat recovery

This unit is specially designed to change the air in your home. This air exchanger will ensure continuous ventilation on request. In winter, it will dehumidify the ambient air to the level set on the control. Odours will also be exhausted and the life span of your house will be extended.

a Box contents

Check if all the parts are included in the package.

- Air exchanger
- Bag of pieces
 - 2x 3/8 & 1/2 universal drain
 - 2x Seal brommets
 - 2x Drain taps
 - 1x Drain hose "T" connector
 - 12' drain hose

b Installation kit contents

Additional parts can be bought to complete the installation. The following parts are recommended for a standard installation.

- Hygrostat
- Cable for hygrostat
- Inlet and exhaust louver
- Inlet grille or diffuser
- Insulated duct
- Non-insulated duct

a Of the unit

The AIR2000 unit should be installed in an area where the temperature is always above the freezing point.

The best location for the unit would minimize the total duct length and the number of elbows. The shorter the ducts and the fewer elbows there are, the higher the airflow will be.

b Of inlet grilles

The ambient air inlet grilles should be mounted close to areas with high humidity levels. Most of the time, they are located in the corridor between the kitchen and the washroom on the ground floor and close to the washroom in the basement. It should not be located in a room containing a combustion appliance like a furnace or a fireplace. The grilles can be installed on the ceiling or a wall. Place the grille within 12" (30cm) of the ceiling.

c Of diffusers

The diffusers are normally installed in corridors as far from the ambient air intake as possible. This forces the air to circulate through most of the house.

The diffuser can be installed on a wall or on the ceiling. If it is located in an occupied area, we recommend mounting the diffuser on the ceiling. This allows the fresh air to be mixed with the ambient air before reaching the occupants, thus improving the comfort level during a cold winter day. A wall-mounted diffuser should be located within 12" (30 cm) of the ceiling.

d Of the humidity control

The control has to be installed where excess humidity is more likely to be detected. On the ground floor, this place is generally located between the kitchen and the bathroom.

If you wish to control the humidity level mainly in the basement you should install the control in this area. Avoid placing the humidistat in an area with stagnant air, for example behind a door.

The installation of the air exchanger must be in accordance with the applicable codes in your area.

a of the unit

The unit is designed to be installed on a shelf or suspended to the structure. When the unit is on a shelf, it is necessary to have some vibration isolators under its casing to prevent the propagation of noise.

The air exchanger must be leveled horizontally. This is necessary to drain the condensation out of the unit. A drainage pipe should joint the connection in the bottom of the casing to the building drainage system.



b Of the exhaust louver

The exhaust louver is installed through an exterior wall at 4" (10 cm) minimum above ground. Attach the intermediary sleeve to the plastic louver collar with a crew. Seal the gap between the sleeve and the wall.

c Of the inlet louver

The inlet louver is installed through an exterior wall, at more than 6' (185 cm) from the exhaust louver and more than 18" (46 cm) above ground. Make sure the inlet louver is installed so the insulated vent duct, joining it to the cabinet, is as straight as possible.

d Of the humidity control

The control should be mounted on the wall, 5' (150 cm) above the floor.

Drill a hole through the wall so you can pass a wire from the control to the unit. This wire contains 4 wires in different colors. Connect them to the wires coming out of the unit. Follow the color code. The wires are at 24V.

Attach the back part of the control to the wall. Install the plastic cover with the help of the fixing screw and the control button.

e Of the ductwork

To maximize the air exchanger airflow, install the ducts as straight as possible. We recommend galvanized steel ducts for long ductwork because of their ease of cleaning and low flow resistance.

You can run ducts through floors, ceilings, walls or closets and cover them thereafter with gypsum board. Ducts in unheated areas must be insulated. The last 3' (m) of the exhaust duct adjacent to the exhaust louver should be insulated and covered with a vapour barrier.

Refer to page 18 to 25 to find where the ducts can be connected to the unit. Slide end of flexible duct over unit port. Wrap 2" (5cm) wide tape around duct.

If necessary, the gaps between ducts and walls or ceilings can be hidden with the rubber strips.

f Air balancing

The air supplied through the diffuser should be warmer than 54°F (12°C). Colder air would make people uncomfortable and create condensation on ducts surfaces. Balancing dampers should be installed in all the air exchanger ducts. They must be adjusted so the supplied air temperature is higher than the temperature stated above all year round.

The difference between the exhaust and supply airflow rates should be negligible (below 10%). Airflows balancing are especially important in houses with combustion appliances or in area where soil gas is deemed to be a problem. Use airflow measuring stations and a magnetic gage to measure the airflow rates.

The speed of each blower can be independently adjust by turning the adjustment knob located on the top of the electrical box.

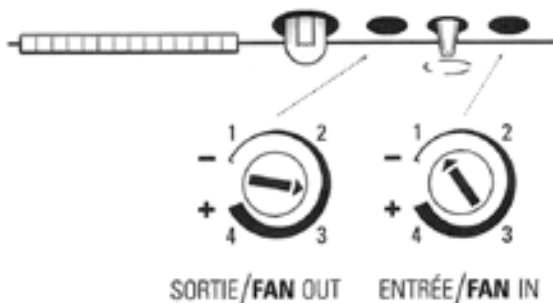

g Unit connection

- Mural accessories

The mural accessories must be installed on the wall at approximately 5' (150cm) from the floor and connected to the device according to the following illustration.

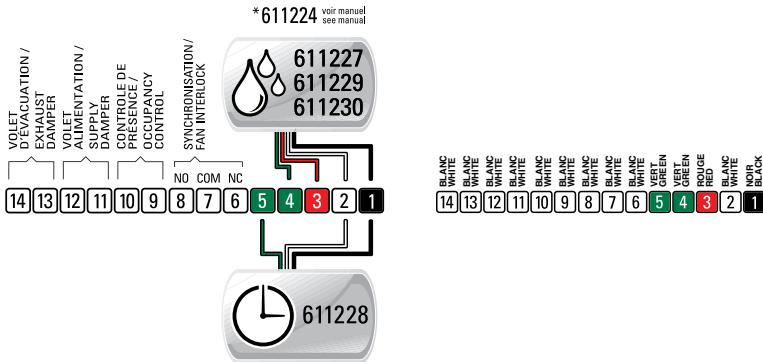

For the connection of the humidistat 611224 or DRY CONTACT, see the following illustrations according to the installation needs.

WITHOUT recirculation option

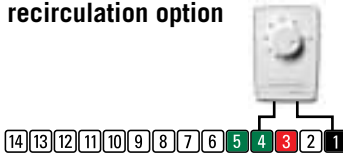

WITH recirculation option

Option 1: the unit is in EXCHANGE mode at DEFAULT SPEED

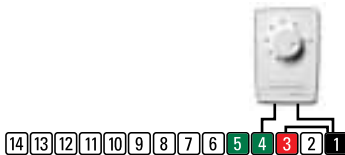

Option 2: the unit is in RECIRCULATION mode at DEFAULT SPEED

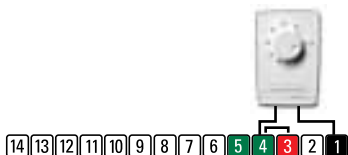

- **Synchronisation contact**

The unit disposes of a dry contact either NO or NC for synchronization with a pulsated air system or other.



- **Occupancy Control**

This dry contact offers a unit operation priority control; it can be used to connect a programmable timer or a motion detector to limit the unit's operation periods. When this contact is activated, the unit functions normally according to the mural accessories.

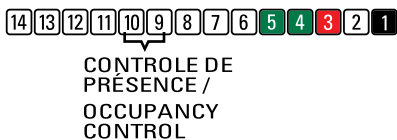

- **Supply and exhaust damper**

These contacts make it possible to feed two damper actuator; one for the supply airstreams and one for the exhaust airstreams (24VAC, 10VA max each).

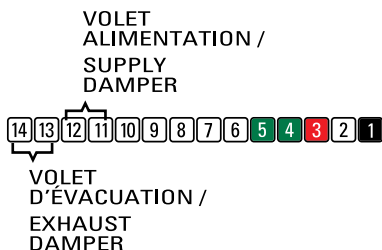

h Unit configuration

It is possible to change the defrost parameters and speed range using the jumper on the configuration port. The configuration port is located on the control board as indicated on the figure below.

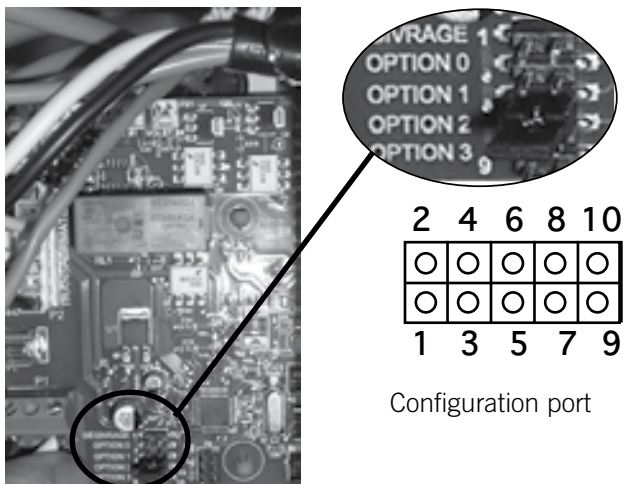

Configuration port

- **EXTENDED DEFROST Option**

For the severe applications, it is possible to extend defrost period in order to prevent ice build-up in the unit. To activate the extended defrost option, add a jumper on the configuration port between terminals 1 and 2 (DEGIVRAGE position).

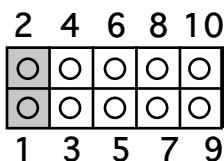

- **REDUCED SPEED Option**

To operate the unit according to the REDUCED speed range (see data sheet for performance), add a jumper on the configuration port between terminals 3 and 4 (OPTION 0 position).

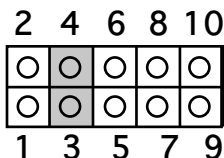

b Humidistat

The humidistat controls the relative humidity rate. Equipped with a humidity sensor and an electronic system, it efficiently controls your air exchanger to keep the humidity rate in your home below the desired setting.

This feature allows you to set the functioning mode of your air exchanger according to your needs. You can create a continuous air exchange with the outside, recirculate ambient air or maintain a constant flow of fresh air when there are more people in the house.

The humidistat is designed to quickly evacuate all excess humidity. When the humidity content exceeds the desired setting, this feature causes air to be exchanged with the outside at a high speed until the humidity has been returned to the desired rate. Afterwards, it will automatically come back to the chosen operating mode.

ASHRE* standards recommend maintaining a relative humidity rate between 30% and 60%.

*(American Society of Heating-Refrigerating and Air Conditioning Engineer)

RECOMMENDED HUMIDITY RATE TO PREVENT INDOOR CONDENSATION	
Outside air temperature	Recommended humidity rate
10°C / 50°F	Between 55 % and 60 %
0°C / 32°F	Between 50 % and 55 %
-10°C / 14°F	Between 45 % and 50 %
-20°C / -4°F	Between 40 % and 45 %
-30°C / -22°F	Between 30 % and 40 %

*These rates may vary according to the type of construction and fenestration of your house.

Humidistat model 611224

The mechanical humidistat controls excess humidity. When the rate of humidity is greater than the value indicated on the adjustment knob, activate the high speed switch and if needed, the interior-exterior exchange switch. When the appropriate humidity rate is reached, the humidistat returns to its pre-selected ventilation mode.

Turn the adjustment knob from the humidity's higher value toward its lower value and, when you hear a click, look at the value indicated. This value represents the rate of ambient moisture in the air.

You may also wish to operate the appliance at high speed. To do this, adjust the knob to its lowest rate of humidity (20%). This setting is recommended for a room full of guests or an extended period of cooking.





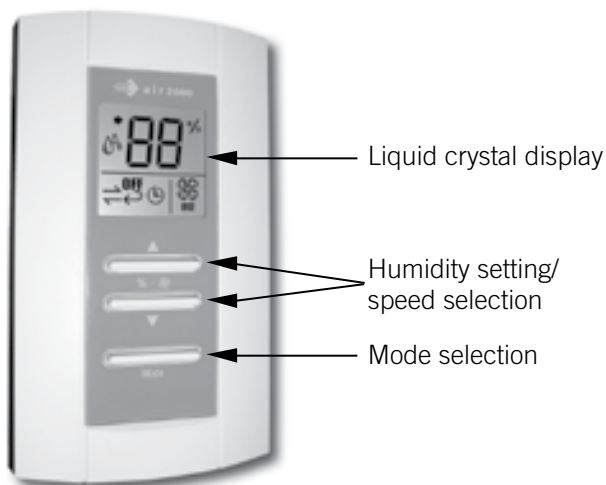

Model 611227

Electronic humidistat with liquid crystal display.

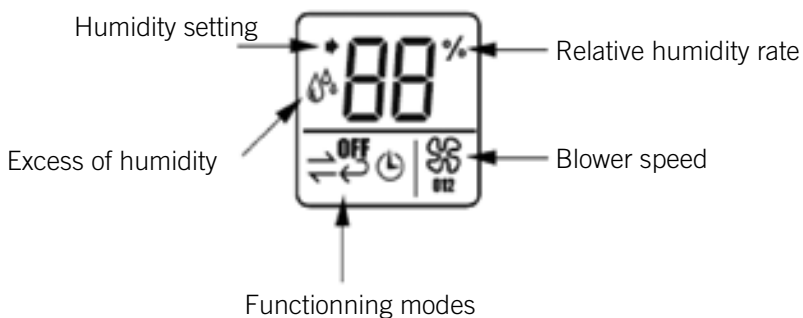











Presentation of the display window



- To adjust the highest humidity setting, use the  until you reach the desired level. This symbol  will be displayed during adjustment.
- Wait several seconds and the relative ambient humidity level will again displayed.
- If the humidity rate exceeds the highest set level, the symbol  will appear and the air exchanger will evacuate the excess humidity. However, if you set the functioning to *OFF*, excess humidity will not be evacuated from the house. (Please see Section 5)



Presentation of the air exchanger's functioning modes

Mode	Speed	Description	Application
OFF	-	Device stops completely. Remains inactive regardless of the humidity rate.	Suspends functioning of the device.
		Paused. Activates only when the humidity rate exceeds the set rate.	Prevents excess humidity. Acts as only as a dehumidifier.
		Exchanges air continuously with outdoors at a low speed.	Achieves an optimum air quality while maintaining an adequate level of humidity.
		Exchanges air continuously with outdoors at a high speed.	Increases the intensity of the fresh air flow when there are visitors or periods of prolonged cooking.
		Recirculates interior air at a low speed.	Equalizes the temperature and humidity in the house.
		Recirculates interior air at a high speed.	Equalizes the temperature more completely (wood stoves).
		Exchanges air with outdoors at a low speed for 20 minutes. Paused for 20 minutes.	Ensures a minimum air circulation and control of humidity during vacations or prolonged absences.
		Exchanges air continuously with outdoors at a low speed for 20 minutes. Recirculates interior air at a low speed for 40 minutes.	Renews interior air and then equalizes the temperature and humidity.

To select one of the available functioning modes for your air exchanger, press the *mode* button until the mode you desire is displayed.

According to the chosen mode, you must adjust the speed of the fans by pressing the up or the down arrow. Once your selection has been made, don't touch the device for several seconds. This allows it to return to a normal display.



c Timer (Product #611228)

Function: Provides the ventilation unit with high-speed exterior exchange for the following durations:

- 20 minutes
- 40 minutes
- 60 minutes



d Maintenance

WARNING: Always disconnect the air exchanger from its power source before attempting any operation inside the unit

Check regularly that the inlet screen and the exhaust screen are not obstructed by ice or particles.

In winter, check every month that the condensate drain opening is not blocked.

Filter to be cleaned with soapy water 3 times a year or when needed.

ATTENTION : Optional high efficiency and charcoal filter are NOT washable

Clean the heat recovery core in the AIR2000 once a year or when needed. Pull out gently the core from the unit. Wear gloves when you handle the core since it can have sharp angles.

Vacuum cabinet interior at least once a year preferably at the beginning of fall.

a Technical sheet for SERIES S700

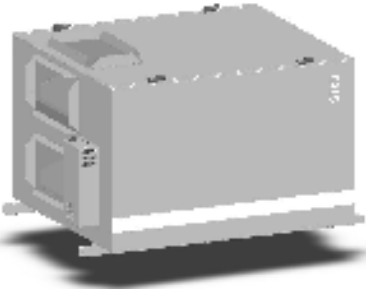

AÉROMATIC S700

The AÉROMATIC S700 is a heat recovery ventilator of 700 CFM. This heat recovery ventilator is the ideal powerful unit for spacious homes, businesses, daycare centers, clinics, bars, restaurants, etc.

The AÉROMATIC S700 is the ultimate solution to prevent excess humidity and improve air quality. Optional version with air recirculation system is available.

- High performance air flow
- Silent
- Highly cost effective and cost efficient

Norms and certifications

- Conformity to Norm :
 1. C22.2 no113
 2. UL 507

- Certified



Casing

Material : Pre-painted steel 22GA
 Insulation : 1" foil faced fibreglass
 Drain connection : Ø3/8" or Ø ½"
 Duct diameter: 8 in x 14 in
 Height : 23 7/8 in
 Width : 36 1/4 in
 Depth : 32 1/4 in
 Weight : 150 lbs

Blowers

Number : 2
 Type: backward curved centrifugal fans

Mount

Suspended by chains with anti-vibration springs or on a shelf

Electrical Specifications

Tension : 120 VAC – 230 VAC
 Frequency : 60 Hz
 Amperage : 5.5 A – 2.9 A
 Power : 660 Watt
 Electrical wiring :

- Extension cord (120VAC; S700-A)
- Field wired (230VAC; S700-B)

Control

Low voltage dry contact (24 VAC 20Va) for :

- Occupancy control (start / stop)
- Speed selection
- Exchange / recirculation (optional)

24VAC 10VA output for :

- Supply air damper
- Exhaust air damper

Compatible with :

- Liquid crystal display electronic humidistat (no 611227)
- Mode Control (exchange or recirculation) (no 611230)
- Humidity Control (no 611224)
- Speed Control (intermittent, high or low speed) (no 611229)
- Timer (no 611228)

Defrost

Cycles Controlled by a temperature sensor

- By exhaust only
- By recirculation (optional)

DEFROST CYCLE TEMPERATURE

Outside temperature Celsius	Standard Fahrenheit	Standard min def/vent	Extended min def/vent
t > -5	t > 23	n.a.	n.a.
-5 > t > -25	23 > t > -13	7/25	10/20
-25 > t	-13 > t	10/22	10/15

Filters

Number : 4

Type (standard) : Washable, aluminum (no 683901)

Options and restriction

Airflow (CFM)	MERV 8	Charcoal	High-Efficiency
300	0,03	0,03	0,03
500	0,08	0,08	0,08
700	0,15	0,15	0,15

Dimensions : 13 3/4 in X 15 in X 7/8 in

Recovery Core

Material : Aluminium
 Performance certifiée :



Quantity : 2

Dimensions : 12 in X 12 in X 15 in
 Step : 2.5mm

Warranty

Appliance : limited 2 years
 Core Assembly : limited 15 years

S700

VENTILATION PERFORMANCE

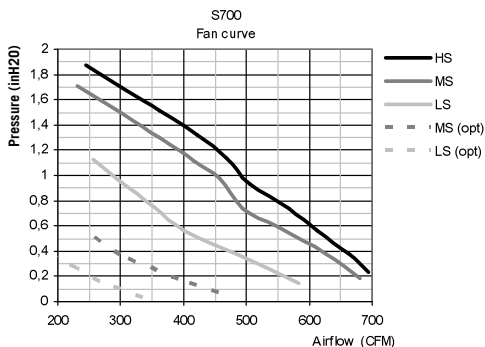
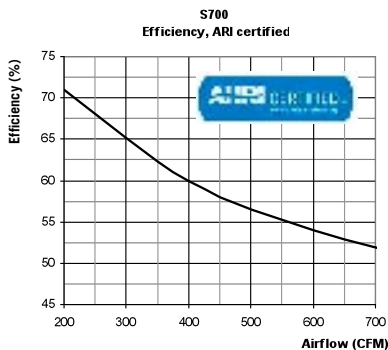

DIMENSIONS

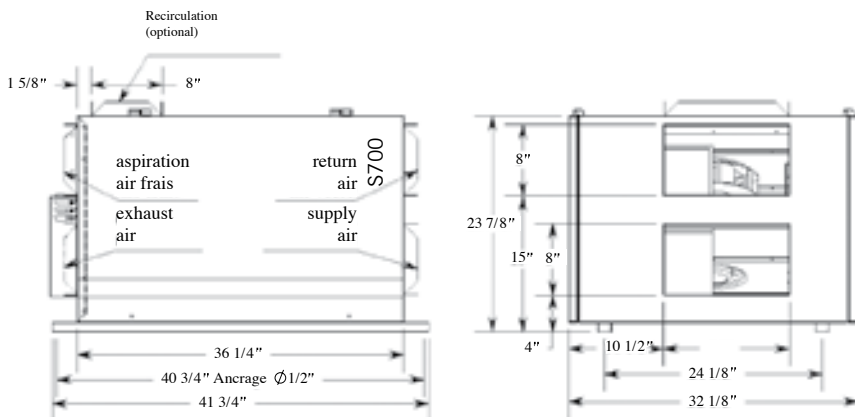

Model, options and product number

UNIT :

Tension	Model #	Product #	Qty
120VAC	S700-A	683302	
230VAC	S700-B	638352	

OPTIONS :

Description	Product #	Qty
Recirculation	683900	
Aluminum filter (replacement)	683901	
MERV 8 filter	683902	
Charcoal filter	683903	
High efficiency filter	683904	

Submitted by :

Date :
Project :
Location :
Architect :
Engineer :
Contractor :
Remarks :

a Technical sheet for SERIES E700

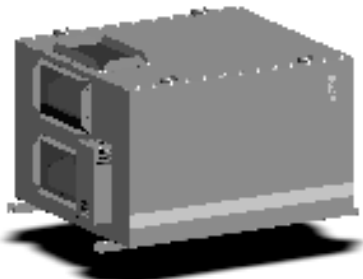

AÉROMATIC E700

The AÉROMATIC E700 is a heat recovery ventilator of 700 CFM. This heat recovery ventilator is the ideal powerful unit for spacious homes, businesses, daycare centers, clinics, bars, restaurants, etc.

The AÉROMATIC E700 is the ultimate solution to prevent excess humidity and improve air quality. Optional version with air recirculation system is available.

- High performance air flow
- Silent
- Highly cost effective and cost efficient

Norms and certifications

- Conformity to Norm :

1. C22.2 no113
2. UL 507

- Certified



Casing

Material : Pre-painted steel 22GA
 Insulation : 1" foil faced fibreglass
 Drain connection : Ø3/8" or Ø 1/2"
 Duct diameter: 8 in x 14 in
 Height : 23 7/8 in
 Width : 36 1/4 in
 Depth : 32 1/4 in
 Weight : 150 lbs

Blowers

Number : 2
 Type: backward curved centrifugal fans

Mount

Suspended by chains with anti-vibration springs or on a shelf

Electrical Specifications

Tension : 120 VAC – 230 VAC

Frequency : 60 Hz

Amperage : 5.5 A – 2.9 A

Power : 660 Watt

Electrical wiring :

- Extension cord (120VAC; E700-A)
- Field wired (230VAC; E700-B)

Control

Low voltage dry contact (24 VAC 20Va) for :

- Occupancy control (start / stop)
- Speed selection
- Exchange / recirculation (optional)

24VAC 10VA output for :

- Supply air damper
- Exhaust air damper

Compatible with :

- Liquid crystal display electronic humidistat (no 611227)
- Mode Control (exchange or recirculation) (no 611230)
- Humidity Control (no 611224)
- Speed Control (intermittent, high or low speed) (no 611229)
- Timer (no 611228)

Defrost

Cycles Controlled by a temperature sensor

- By exhaust only
- By recirculation (optional))

DEFROST CYCLE TEMPERATURE

Outside temperature Celsius	Standard Fahrenheit	Standard min def/vent	Extended min def/vent
t > -5	t > 23	n.a.	n.a.
-5 > t > -25	23 > t > -13	7/25	10/20
-25 > t	-13 > t	10/22	10/15

Filters

Number : 4

Type (standard) : Washable, aluminum (no 683901)

Options and restriction

Airflow (CFM)	MERV 8	Charcoal	High-Efficiency
300	0,03	0,03	0,03
500	0,08	0,08	0,08
700	0,15	0,15	0,15

Dimensions : 13 3/4 in X 15 in X 7/8 in

Recovery Core

Material : Aluminium

Performance certifiée :



Quantity : 2

Dimensions : 12 in X 12 in X 15 in

Step : 2.5mm

Warranty

Appliance : limited 2 years

Core Assembly : limited 3 years

E700

VENTILLATION PERFORMANCE

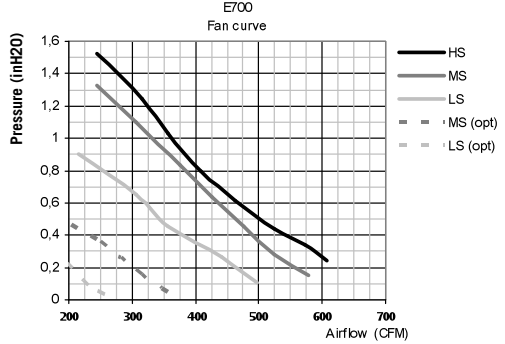
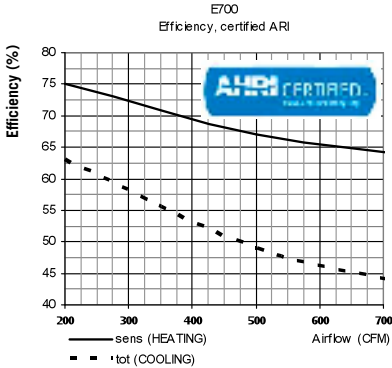

DIMENSIONS

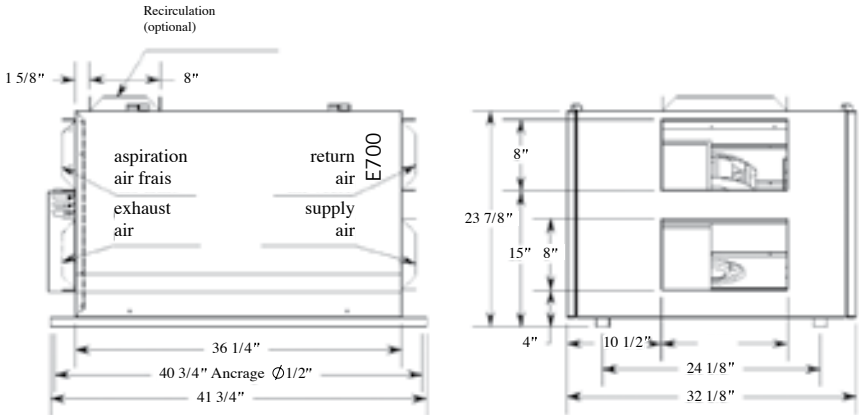

Model, options and product number

UNIT :

Tension	Model #	Product #	Qty
120VAC	E700-A	683304	
230VAC	E700-B	638354	

OPTIONS :

Description	Product #	Qty
Recirculation	683900	
Aluminum filter (replacement)	683901	
MERV 8 filter	683902	
Charcoal filter	683903	
High efficiency filter	683904	

Submitted by :

Date :

Project :

Location :

Architect :

Engineer :

Contractor :

Remarques :

a Technical sheet for SERIES S1100

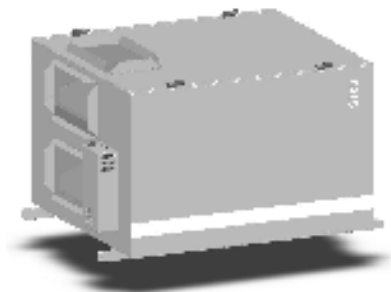

AÉROMATIC S1100

The AÉROMATIC S1100 is a heat recovery ventilator of 700 CFM. This heat recovery ventilator is the ideal powerful unit for spacious homes, businesses, daycare centers, clinics, bars, restaurants, etc.

The AÉROMATIC S1100 is the ultimate solution to prevent excess humidity and improve air quality. Optional version with air recirculation system is available.

- High performance air flow
- Silent
- Highly cost effective and cost efficient

Norms and certifications

- Conformity to Norm :

1. C22.2 no113
2. UL 507

- Certified



Casing

Material : Pre-painted steel 22GA
 Insulation : 1" foil faced fibreglass
 Drain connection : Ø3/8" or Ø ½"
 Duct diameter: 8 in x 14 in
 Height : 23 7/8 in
 Width : 36 1/4 in
 Depth : 32 1/4 in
 Weight : 150 lbs

Blowers

Number : 2
 Type: backward curved centrifugal fans

Mount

Suspended by chains with anti-vibration springs or on a shelf

Electrical Specifications

Tension : 120 VAC – 230 VAC
 Frequency : 60 Hz
 Amperage : 5.5 A – 2.9 A
 Power : 660 Watt
 Electrical wiring :

- Extension cord (120VAC; S1100-A)
- Field wired (230VAC; S1100-B)

Control

Low voltage dry contact (24 VAC 20Va) for :

- Occupancy control (start / stop)
- Speed selection
- Exchange / recirculation (optional)

24VAC 10VA output for :

- Supply air damper
- Exhaust air damper

Compatible with :

- Liquid crystal display electronic humidistat (no 611227)
- Mode Control (exchange or recirculation) (no 611230)
- Humidity Control (no 611224)
- Speed Control (intermittent, high or low speed) (no 611229)
- Timer (no 611228)

Defrost

Cycles Controlled by a temperature sensor

- By exhaust only
- By recirculation (optional))

DEFROST CYCLE TEMPERATURE

Outside temperature Celsius	Standard Fahrenheit	Extended min def/vent	min def/vent
t > -5	t > 23	n.a.	n.a.
-5 > t > -25	23 > t > -13	7/25	10/20
-25 > t	-13 > t	10/22	10/15

Filters

Number : 4

Type (standard) : Washable, aluminum (no 683901)

Options and restriction

Airflow (CFM)	MERV 8	Charcoal	High-Efficiency
300	0,03	0,03	0,03
500	0,08	0,08	0,08
700	0,15	0,15	0,15

Dimensions : 13 3/4 in X 15 in X 7/8 in

Recovery Core

Material : Aluminium
 Performance certifiée :



Quantity : 2

Dimensions : 12 in X 12 in X 15 in
 Step : 2.5mm

Warranty

Appliance : limited 2 years
 Core Assembly : limited 15 years

S1100

VENTILLATION PERFORMANCE

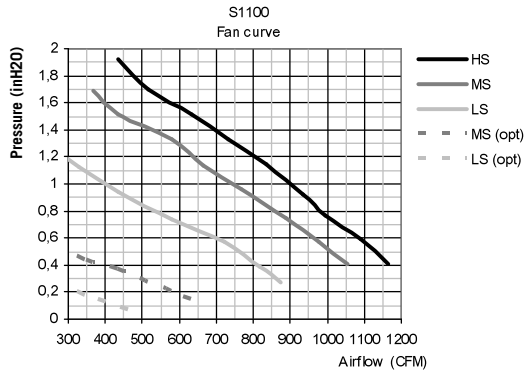
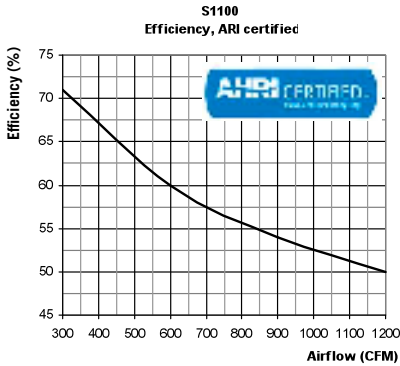

DIMENSIONS

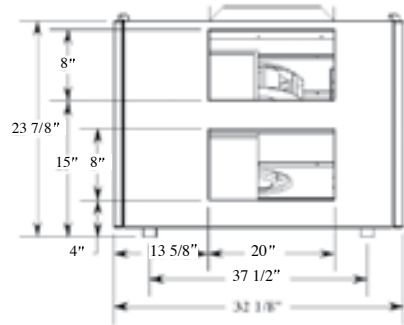
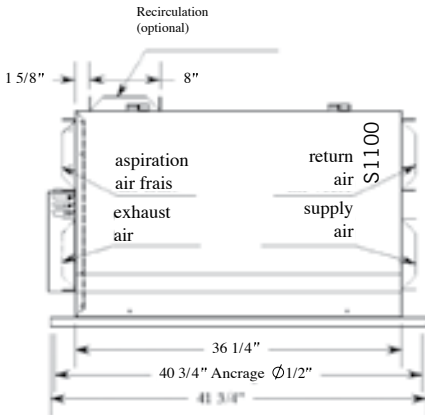

Model, options and product number

UNIT :			
Tension	Model #	Product #	Qty
120VAC	E700-A	683304	
230VAC	E700-B	638354	

OPTIONS :			
Description	Product #	Qty	
Recirculation	683900		
Aluminum filter (replacement)	683901		
MERV 8 filter	683902		
Charcoal filter	683903		
High efficiency filter	683904		

Submitted by :	
Date :	
Project :	
Location :	
Architect :	
Engineer :	
Contractor :	
Remarques :	

a Technical sheet for SERIES E1100



AÉROMATIC E1100

The AÉROMATIC E1100 is a heat recovery ventilator of 700 CFM. This heat recovery ventilator is the ideal powerful unit for spacious homes, businesses, daycare centers, clinics, bars, restaurants, etc.

The AÉROMATIC S1100 is the ultimate solution to prevent excess humidity and improve air quality. Optional version with air recirculation system is available.

- High performance air flow
- Silent
- Highly cost effective and cost efficient

Norms and certifications

- Conformity to Norm :

1. C22.2 no113
2. UL 507

- Certified



Casing

Material : Pre-painted steel 22GA
 Insulation : 1" foil faced fibreglass
 Drain connection : Ø3/8" or Ø ½"
 Duct diameter: 8 in x 14 in
 Height : 23 7/8 in
 Width : 36 1/4 in
 Depth : 32 1/4 in
 Weight : 150 lbs

Blowers

Number : 2
 Type: backward curved centrifugal fans

Mount

Suspended by chains with anti-vibration springs or on a shelf

Electrical Specifications

Tension : 120 VAC – 230 VAC

Frequency : 60 Hz

Amperage : 5.5 A – 2.9 A

Power : 660 Watt

Electrical wiring :

- Extension cord (120VAC; E1100-A)
- Field wired (230VAC; E1100-B)

Control

Low voltage dry contact (24 VAC 20Va) for :

- Occupancy control (start / stop)
- Speed selection
- Exchange / recirculation (optional)

24VAC 10VA output for :

- Supply air damper
- Exhaust air damper

Compatible with :

- Liquid crystal display electronic humidistat (no 611227)
- Mode Control (exchange or recirculation) (no 611230)
- Humidity Control (no 611224)
- Speed Control (intermittent, high or low speed) (no 611229)
- Timer (no 611228)

Defrost

Cycles Controlled by a temperature sensor

- By exhaust only
- By recirculation (optional)

DEFROST CYCLE TEMPERATURE

Outside temperature Celsius	Fahrenheit	Standard		Extended	
		min def/vent	min def/vent	min def/vent	min def/vent
t > -5	t > 23	n.a.	n.a.	n.a.	n.a.
-5 > t > -25	23 > t > -13	7/25	10/20	10/20	10/20
-25 > t	-13 > t	10/22	10/22	10/15	10/15

Filters

Number : 4

Type (standard) : Washable, aluminum (no 683901)

Options and restriction

Airflow (CFM)	MERV 8	Charcoal	High-Efficiency
300	0,03	0,03	0,03
500	0,08	0,08	0,08
700	0,15	0,15	0,15

Dimensions : 13 3/4 in X 15 in X 7/8 in

Recovery Core

Material : Aluminium

Performance certifiée :



Quantity : 2

Dimensions : 12 in X 12 in X 15 in

Step : 2.5mm

Warranty

Appliance : limited 2 years

Core Assembly : limited 3 years

E1100

VENTILLATION PERFORMANCE

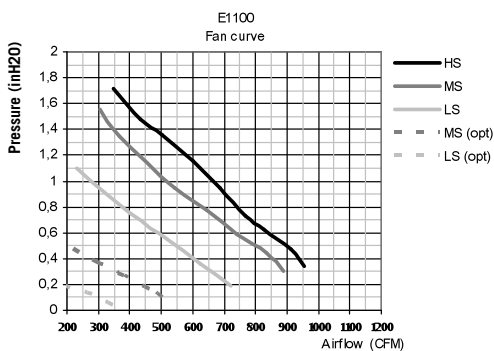
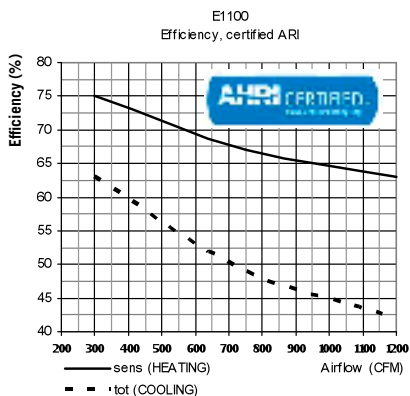

DIMENSIONS

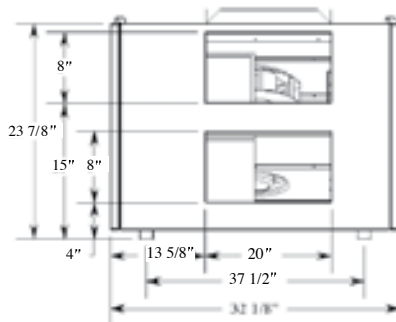
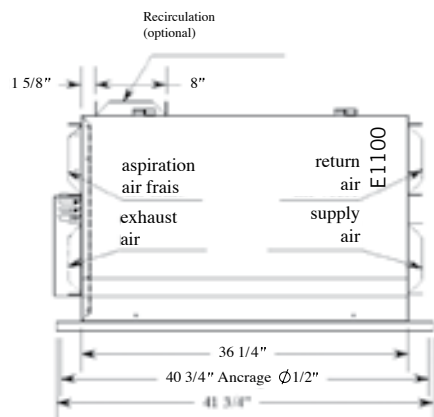

Model, options and product number

UNIT :			
Tension	Model #	Product #	Qty
120VAC	E700-A	683304	
230VAC	E700-B	638354	

OPTIONS :			
Description	Product #	Qty	
Recirculation	683900		
Aluminum filter (replacement)	683901		
MERV 8 filter	683902		
Charcoal filter	683903		
High efficiency filter	683904		

Submitted by :	
Date :	
Project :	
Location :	
Architect :	
Engineer :	
Contractor :	
Remarques :	

e Warranty

We guarantee this product and all its components to be free from defects in material and factory workmanship for a period of 2 years

This warranty plan does not cover any defect resulting from improper installation, misuse, acts of God and/or other similar causes beyond the control of the manufacturer.

AIR2000 shall not be liable for implied or expressed warranty for damages or indemnity.

Neither shall AIR2000 be responsible for any injury or ham caused directly or indirectly by our ventilation units.

How to claim

Any claim concerning a defective unit or any of its components should be submitted to AIR2000 who will replace it by an identical or a similar part or will repair it according to the advice of the company's representative.

The cost for removal and installation of the defective parts is not covered by this actual warranty.

We recommend talking with one of our technicians before removing any unit. He can probably indicate another way to solve the problem.

Obtain an authorization number from our customer service department before sending a unit for service.

Please forward the defective part prepaid to the address below. It will be returned to you prepaid.

